

Ouachita Baptist University

## Scholarly Commons @ Ouachita

---

Honors Theses

Carl Goodson Honors Program

---

5-1974

# Response of Insects to U.V. Light and Varying Intensities of White Light

Tim Matthews

*Ouachita Baptist University*

Follow this and additional works at: [https://scholarlycommons.obu.edu/honors\\_theses](https://scholarlycommons.obu.edu/honors_theses)



Part of the [Entomology Commons](#)

---

### Recommended Citation

Matthews, Tim, "Response of Insects to U.V. Light and Varying Intensities of White Light" (1974). *Honors Theses*. 549.

[https://scholarlycommons.obu.edu/honors\\_theses/549](https://scholarlycommons.obu.edu/honors_theses/549)

This Thesis is brought to you for free and open access by the Carl Goodson Honors Program at Scholarly Commons @ Ouachita. It has been accepted for inclusion in Honors Theses by an authorized administrator of Scholarly Commons @ Ouachita. For more information, please contact [mortensona@obu.edu](mailto:mortensona@obu.edu).

## V. ANALYSIS OF RESULTS

Although theoretically insects react more strongly to ultraviolet light than to ordinary white light, such was not the case in this experiment. There are several reasons for this deviation from the expected. One is the fact that there were other lights (within the range of the insects' vision) of greater intensity than those lights used in the experiment. This would cause the insects to react towards the more intense light source instead of the collector light. Although this reinforces the previously stated theory of "the greater the intensity, the greater the response", it voids the results concerning the insects reaction to ultraviolet light.

Ultraviolet light will draw more response than a white light of corresponding intensity, but there is a point at which the intensity will over-rule the response to the ultraviolet light.

Another factor that may have led to incorrect results is that of the intensity of the moon-light. On cloudy nights the response was greater than the response elicited on clear nights.

The temperature also had a very definite effect on the results. The lower the temperature the less the response. This relationship between temperature and response is an indirect one rather than a direct one. It is most likely that the temperature either killed or slowed down the insects, and did not actually effect the electro-chemical response.

In order to obtain valid results one would need to maintain strict controls on the temperature, wind currents, surroundings and humidity. The method of using the numbers of insects collected as the basis for experimental conclusions about the response of insects to variations of intensity and wave-length is not actually a valid method. A more precise method would be to record (if possible) the electrical responses of a single visual cell of the compound eye.

RESPONSE OF INSECTS TO U.V. LIGHT  
AND VARYING INTENSITIES OF WHITE LIGHT

I. OBJECT : To determine the sensitivity of insects to ultraviolet light and also to verify their response to varying intensities of white light.

II. THEORY: Insects are generally sensitive to light of any wave-length. Some insects' reactions are due to the response of specialized epidermal cells whereas the center of most response is in the compound eye. The reaction is generally thought to be due to an electro-chemical reaction within the light sensitive cells of the compound eye, i.e. mainly the cells of the crystalline cone and the rhabdomere. Insects tend to react more strongly to light in the ultraviolet region although the mechanism(s) which cause this reaction have not been established.

It has been observed experimentally that the magnitude of the insects' response to white light is directly proportional to the intensity of the light. The actual cause of this response has also not been determined.

III. APPARATUS: Diagrams of the apparatus used are on the following page.

1. Box collector - for white light

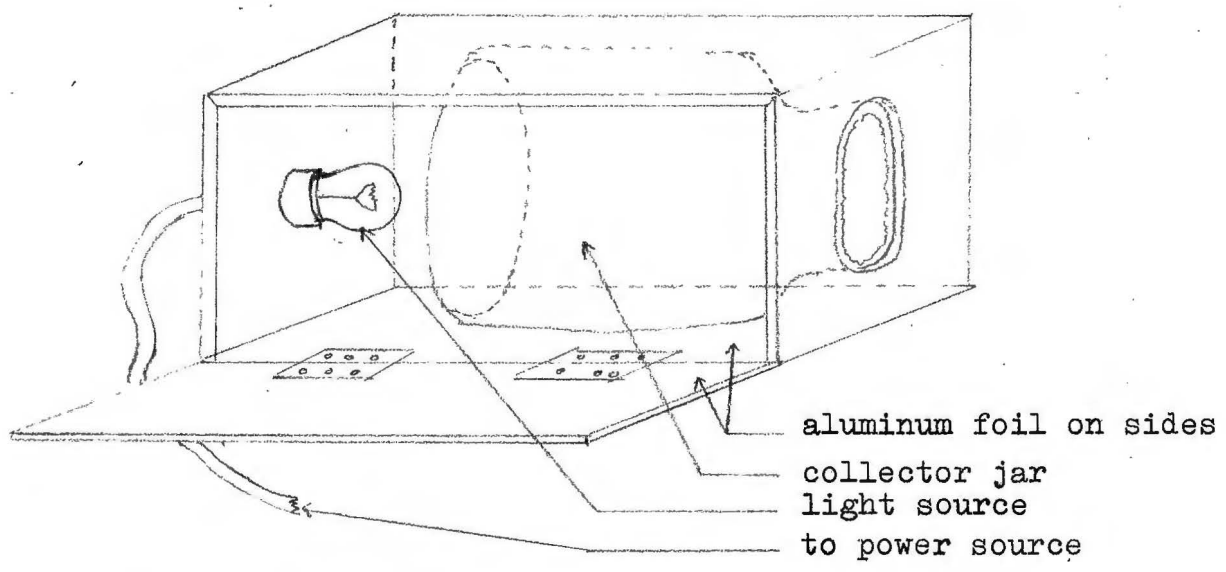

2. Funnel collector

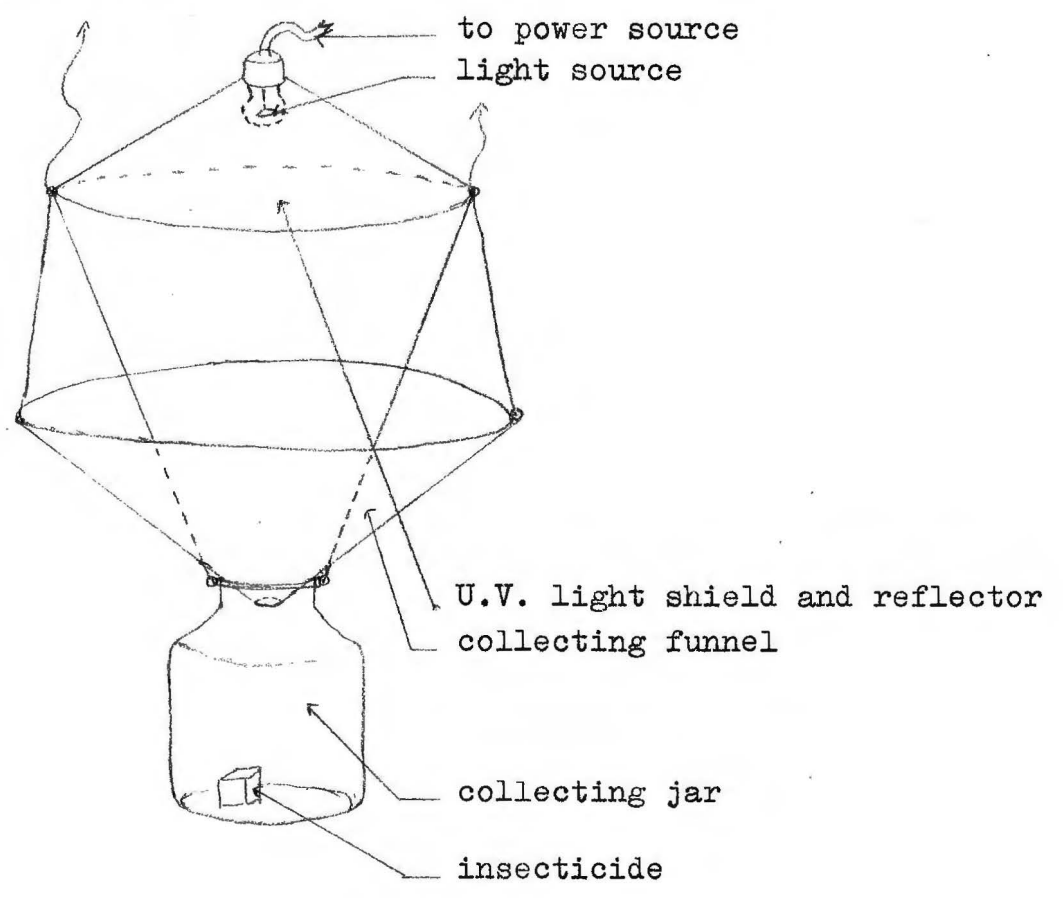

IV. DATA  
FALL 1973

A. Box  
250 Watt - white light

| DATE     | CATCH | TIME | REMARKS                               |
|----------|-------|------|---------------------------------------|
| 10/9/73  | 5     | 2"   | Weather- clear, cool                  |
| "        | 4     | 5"   |                                       |
| "        | 5     | 15"  |                                       |
| "        | 4     | 30"  |                                       |
| 10/11/73 | 7     | 2"   | Weather- clear, cool, humid           |
| "        | 4     | 5"   |                                       |
| "        | 5     | 15"  |                                       |
| "        | 6     | 30"  |                                       |
| 10/15/73 | 4     | 5"   | Weather- cool, humid                  |
| "        | 3     | 5"   | Began using only 5" exposure time.    |
| "        | 4     | 5"   |                                       |
| 10/19/73 | 3     | 5"   | Damp. cooler (below 60°F)             |
| "        | 2     | 5"   |                                       |
| "        | 4     | 5"   |                                       |
| 10/25/73 | 2     | 5"   | Too cool for any reasonable response. |
| "        | 3     | 5"   |                                       |
| "        | 2     | 5"   |                                       |
| 11/3/73  | 1     | 5"   | Weather cool                          |
| "        | -     | 5"   |                                       |
| "        | -     | 5"   |                                       |
| 11/20/73 | -     | 5"   | Weather cool. Cold spell last week.   |
| "        | -     | 5"   |                                       |
| "        | -     | 5"   |                                       |

B. Box  
100 Watt - white light

| DATE     | CATCH | TIME | REMARKS                                 |
|----------|-------|------|---|
| 10/9/73  | 4     | 2"   | Weather clear, cool.                    |
| "        | 4     | 5"   |   |
| "        | 3     | 15"  |   |
| "        | 5     | 30"  |   |
| 10/11/73 | 3     | 2"   | Weather - clear, cool, humid            |
| "        | 2     | 5"   |   |
| "        | 5     | 15"  |   |
| "        | 3     | 30"  |   |
| 10/15/73 | 3     | 5"   | Almost all of the catch was mosquitoes. |
| "        | 2     | 5"   |   |
| "        | 2     | 5"   |   |
| 10/19/73 | 1     | 5"   | Damp. Cooler (below 60 F)               |
| "        | 2     | 5"   |   |
| "        | -     | 5"   |   |
| 10/25/73 | 1     | 5"   | Temp. too low.                          |
| "        | 2     | 5"   |   |
| "        | -     | 5"   |   |
| 11/3/73  | -     | 5"   | Weather cool.                           |
| "        | -     | 5"   |   |
| 11/20/73 | 1     | 5"   | Weather cool.                           |
| "        | -     | 5"   |   |

C. Box  
75 Watt - white light

| DATE     | CATCH | TIME |
|----------|-------|------|
| 10/9/73  | 3     | 2"   |
| "        | 3     | 5"   |
| "        | 4     | 15"  |
| "        | 1     | 30"  |
| 10/11/73 | -     | 2"   |
| "        | 4     | 5"   |
| "        | 2     | 15"  |
| "        | 3     | 30"  |
| 10/15/73 | 2     | 5"   |
| "        | 1     | 5"   |
| "        | -     | 5"   |

| DATE     | CATCH | TIME | REMARKS  |
|----------|-------|------|--|
| 10/19/73 | 2     | 5"   | Temperature probably too low for this intensity. |
| "        | -     | 5"   |  |
| "        | -     | 5"   |  |
| 10/25/73 | -     | 5"   | Weather too cool.                                |
| "        | -     | 5"   |  |
| 11/3/73  | -     | 5"   | Cold   |
| "        | -     | 5"   |  |
| 11/20/73 | -     | 5"   | Cold - These runs act as controls.               |
| "        | -     | 5"   |  |

D. Box  
15 Watt - white light

| DATE     | CATCH | TIME |
|----------|-------|------|
| 10/9/73  | 2     | 2"   |
| "        | -     | 5"   |
| "        | -     | 15"  |
| "        | -     | 30"  |
| 10/11/73 | -     | 2"   |
| "        | 3     | 5"   |
| "        | -     | 15"  |
| "        | -     | 30"  |
| 10/15/73 | -     | 5"   |
| "        | -     | 5"   |
| 10/19/73 | 1     | 5"   |
| "        | -     | 5"   |
| 10/25/73 | -     | 5"   |
| "        | -     | 5"   |

No other responses were observed for this intensity of white light.

\* All experiments made during the Fall were done behind LakeSide towards the ravine.

E. Funnel  
15 Watt - ultraviolet

| DATE    | CATCH | TIME | REMARKS                 |
|---------|-------|------|-------------------------|
| 3/27/74 | 2     | 2"   | Weather cool. Windy.    |
| "       | 2     | 5"   |                         |
| "       | 1     | 15"  |                         |
| "       | -     | 30"  |                         |
| 4/5/74  | 4     | 2"   | Temp. in 70's F.        |
| "       | 3     | 5"   | Overcast                |
| "       | 5     | 15"  |                         |
| "       | 2     | 30"  |                         |
| 4/6/74  | 4     | 15"  | Weather clear and warm. |
| "       | 2     | 15"  |                         |
| "       | 1     | 15"  |                         |
| "       | 1     | 15"  |                         |
| "       | 1     | 15"  |                         |
| "       | -     | 15"  |                         |
| "       | 3     | 15"  |                         |
| "       | -     | 15"  |                         |
| 4/12/74 | 2     | 15"  | Partly cloudy. Warm -   |
| "       | 1     | 15"  |                         |
| "       | 3     | 15"  |                         |
| "       | -     | 15"  |                         |
| "       | -     | 15"  |                         |
| "       | 1     | 15"  |                         |
| 4/13/74 | -     | 15"  | Cloudy and warm.        |
| "       | -     | 15"  |                         |
| "       | 2     | 15"  |                         |
| "       | 2     | 15"  |                         |
| "       | -     | 15"  |                         |
| "       | -     | 15"  |                         |
| 4/20/74 | -     | 15"  |                         |
| "       | 2     | 15"  |                         |
| "       | -     | 15"  |                         |
| "       | -     | 15"  |                         |
| "       | 1     | 15"  |                         |



| DATE    | CATCH | TIME | REMARKS                               |
|---------|-------|------|---------------------------------------|
| 4/26/74 | 1     | 15"  | with insecticide(commercial)          |
| "       | 1     | 15"  |                                       |
| "       | -     | 15"  | without insecticide                   |
| "       | -     | 15"  | Weather damp. Partly cloudy.          |
| "       | -     | 15"  |                                       |
| 4/28/74 | 1     | 15"  | Used Arsenic compound as insecticide. |
| "       | -     | 15"  |                                       |
| "       | -     | 15"  | Weather clear.                        |
| "       | 2     | 15"  |                                       |
| "       | -     | 15"  |                                       |

F. Funnel

15 Watt - white light (control)

| DATE    | CATCH | TIME |                       |
|---------|-------|------|-----------------------|
| 3/27/74 | 1     | 2"   |                       |
| "       | 3     | 5"   |                       |
| "       | 3     | 15"  |                       |
| "       | 2     | 30"  |                       |
| 4/5/74  | 3     | 2"   |                       |
| "       | 2     | 5"   |                       |
| "       | 2     | 15"  |                       |
| "       | 5     | 30"  |                       |
| 4/6/74  | 3     | 15"  |                       |
| "       | 1     | 15"  |                       |
| 4/12/74 | 3     | 15"  |                       |
| "       | 1     | 15"  |                       |
| 4/13/74 | -     | 15"  |                       |
| "       | 3     | 15"  |                       |
| 4/20/74 | 3     | 15"  |                       |
| "       | 1     | 15"  |                       |
| 4/26/74 | 5     | 15"  | With insecticide      |
| "       | 2     | 15"  | Without insecticide   |
| 4/28/74 | 1     | 15"  | Used Arsenic compound |
| "       | 3     | 15"  |                       |

\* All experiments, using the funnel as the collector, were done behind Daniel-South (facing the Ouachita River).

## V. ANALYSIS OF RESULTS

Although theoretically insects react more strongly to ultraviolet light than to ordinary white light, such was not the case in this experiment. There are several reasons for this deviation from the expected. One is the fact that there were other lights (within the range of the insects' vision) of greater intensity than those lights used in the experiment. This would cause the insects to react towards the more intense light source instead of the collector light. Although this reinforces the previously stated theory of "the greater the intensity, the greater the response", it voids the results concerning the insects reaction to ultraviolet light.

Ultraviolet light will draw more response than a white light of corresponding intensity, but there is a point at which the intensity will over-rule the response to the ultraviolet light.

Another factor that may have led to incorrect results is that of the intensity of the moon-light. On cloudy nights the response was greater than the response elicited on clear nights.

The temperature also had a very definite effect on the results. The lower the temperature the less the response. This relationship between temperature and response is an indirect one rather than a direct one. It is most likely that the temperature either killed or slowed down the insects, and did not actually effect the electro-chemical response.

In order to obtain valid results one would need to maintain strict controls on the temperature, wind currents, surroundings and humidity. The method of using the numbers of insects collected as the basis for experimental conclusions about the response of insects to variations of intensity and wave-length is not actually a valid method. A more precise method would be to record (if possible) the electrical responses of a single visual cell of the compound eye.

The results of this experiment reinforced the theory of 'the greater the intensity, the greater the response'. The results concerning the response to the ultraviolet light were voided due to the fact that surroundings were not controlled strictly enough.